

RAMAR DEVIL A0-2E

The RAMAR DEVIL is a **vehicle anti-theft device that allows the engine to be left running safely, with the key removed from the ignition.** The engine cuts out as soon as someone attempts to drive away without re-inserting the key in the ignition.

Ideal for → law enforcement
 → emergency services: ambulances, fire brigade
 → breakdown assistance services

where the engine provides the primary source of power.

Vehicles → cars
 → motorbikes
 → commercial vehicles
 → trucks/lorries

The battery keeps charging and provides adequate power to :

- lights (headlights, warning, blue and other scene lights)
- radios
- air conditioning (can be left for dogs)
- other ancillary equipment or electrical accessories

Anti-theft device : without the key, the engine cuts out

- as soon as the handbrake is released
- the foot-brake is applied
- or when the shift lever moves away from 'Park' (automatic transmission)

The RAMAR DEVIL has a long track record as a **robust reliable cost effective** way of ensuring vehicle security whilst in operation, **simple yet effective.**

RAMAR also offers a bespoke service to configure the RAMAR DEVIL to match customer's requirements.

This product must be used in accordance with the Highway Code and current legislation effective in your country relating to road vehicles.

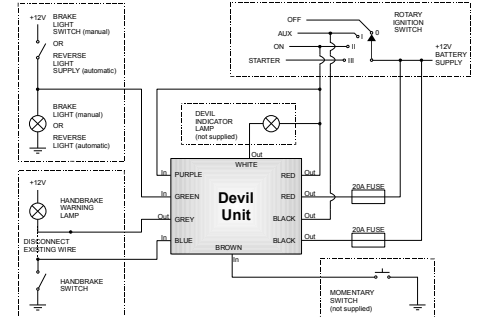
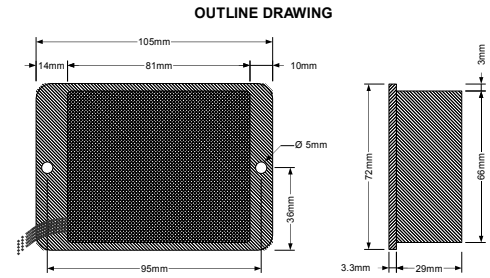

- **Voltage:** 12V DC operation (24V version also available)
- **Outputs:**
 - 2 separate 20A by-passes
 - 1 ground output, which can be used for an Indicator Lamp/LED, or to drive another 10A ancillary
- **Inputs:**
 - 2 battery +12V supplies (power supply to runlock and brake light switch)
 - 1 ground input (handbrake)
 - momentary switch input to ground
- **Dim.:** 105 x 72 x 32 mm³
- **Weight:** 320gr
- **Temp.:** -30°C à 85°C



- Simple installation
- Fully encapsulated
- Momentary "push-to-make" switch and optional runlock indicator lamp/LED not supplied : customer or vehicle specific
- End of line rig test : all units fully validated
- Generic wiring schematics guidelines, installation recommendations and functional validation instructions supplied
- 'E'-marked compliant to 95/54/EC and 89/336/EEC
- Approved for Emergency Vehicle Use by the Home Office VIDG
- 3-year manufacturer warranty
- Made in UK



Tel : +44(0)2081 233346
 email : sales@optimx.eu
 web : www.optimx.eu